



Document/File name MANTTT031E.doc	Document Type External	Revision 6
First Revision, Sign and Date Lan 2002-03-12	Updated Revision, Sign and Date Bln 2018-09-03	Document Status and Sign Approved by Lan
Document and Product Description User Manual Gear Indicator Unit TTT031		Page 1 (4)

General

Gearbox indicator unit for sequential gear boxes with maximum 9 levels. The indicator unit is built around a 8 bit RISC processor. The input for the gearbox sensor is analog (0-5 Volts). There is also one input for sensing the rpm and when the programmed limit is exceeded the gear box unit display turns red.

The indicator unit also has 2 inputs for programming buttons used to setup analog and rpm limits. The picture below shows the display with the optional sunvisor and mounting kit.



Part no. 10-031-5
Part no. 10-109-9

Display with cablekit
Sunvisor and mountingkit

Sensor is not included

Specifications

Power supply: + 12 Volts, Note: Protected against wrong polarity.
Sensor input: 0 – 5 Volts, Note: Do NOT use potentiometer less than 1kohm.
Rpm input: Digital, 0-12 Volt, 1000 to 9900 revs/minute. Note: Do NOT connect directly to ignition coil!
Rpm prescale setting: 1 to 9 pulses/revolution

Document/File name MANTTT031E.doc	Document Type External	Revision 6
First Revision, Sign and Date Lan 2002-03-12	Updated Revision, Sign and Date Bln 2018-09-03	Document Status and Sign Approved by Lan
Page 2 (4)		
Document and Product Description User Manual Gear Indicator Unit TTT031		

Connection

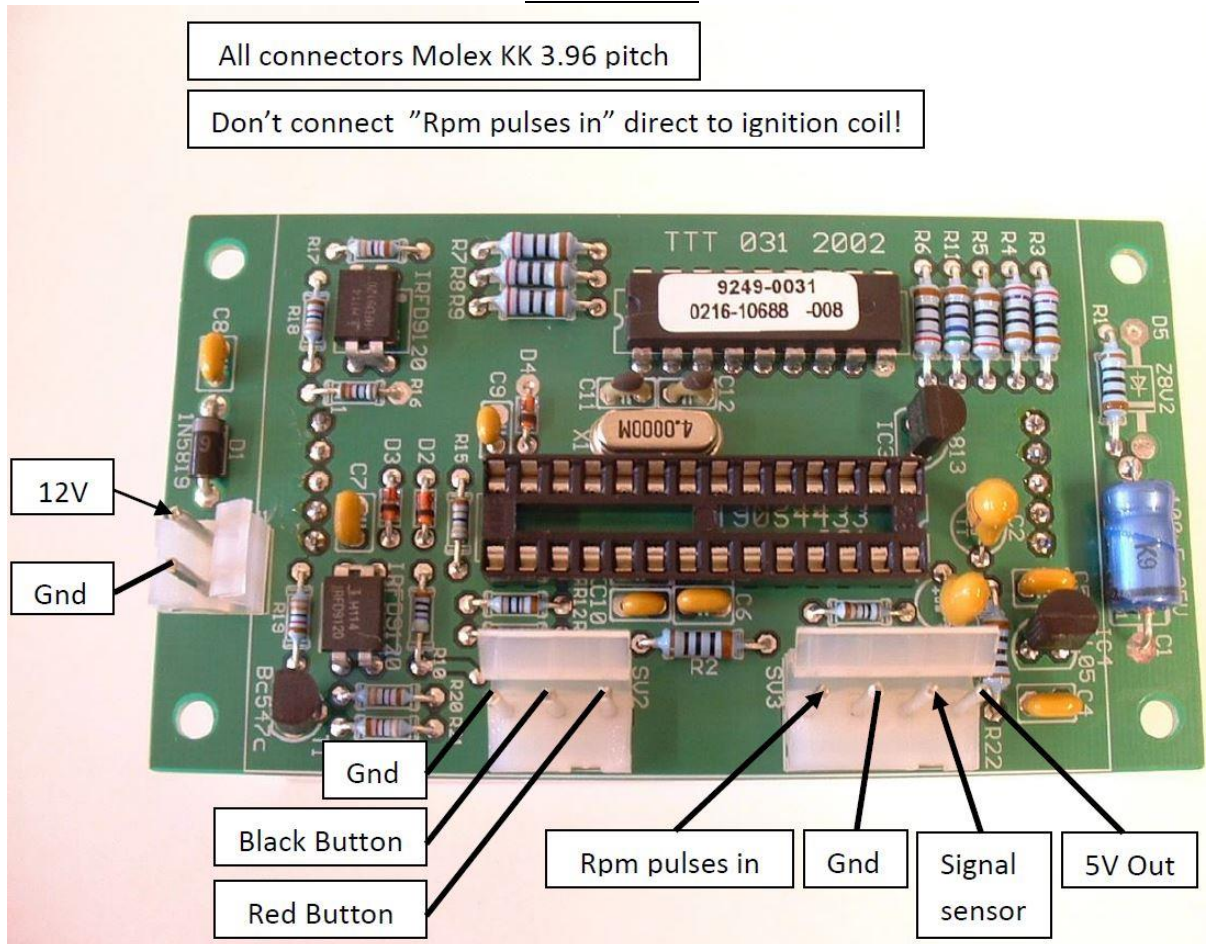

2 pole connector: Power supply

Red + 12 Volts

Black Minus

3 pole connector: Programming buttons.

Note: Only have these connected during setup.

4 pole connector: Gear barrel sensor and rpm input pulses. (Two different types of sensor cables with different lead colors can occur)

Cable type 1 Red, type 2 Blue Sensor + 5 Volts (Output from unit)

Cable type 1 Green, type 2 Brown Sensor signal

Cable type 1 Blue, type 2 Black Sensor minus

Green, Flying wire, Digital Rpm input from ECU or ignition module: 0-12 Volt Rpm pulses. Do **NOT** connect directly to ignition coil! If not used, isolated or remove this cable from the connector housing!!!



Document/File name MANTTT031E.doc	Document Type External	Revision 6	
First Revision, Sign and Date Lan 2002-03-12	Updated Revision, Sign and Date Bln 2018-09-03	Document Status and Sign Approved by Lan	Page 3 (4)
Document and Product Description User Manual Gear Indicator Unit TTT031			

Fixing the barrel sensor / 5 geared Tractive gearbox.

308, 345 or 360 degrees sensor.

Place the gearbox in the 2nd gear.

Adjust the plunch so that the groove is in 90 degrees angle towards an imaginary line between the fastening holes for the sensor.

Before the sensor is put in place its shaft should be rotated so the mark on the shaft points at the connecting cable.

Assembly the sensor onto the gearbox and make sure that the screws are centered in the sensors mounting holes.

Connect the display and turn on the power.

Measure with a digital voltmeter between the barrel sensor signal (cable type 1 = green, type 2 = brown) and minus (cable type 1 = blue, type 2 = black) in the 4-pole connector on the display unit. Adjust by turning the barrel sensor so that this reading is as close as possible to 2,5 Volts. Tighten the fastening screws.

Check by measuring again that tightening the screws did not affect the sensor position.

The sensor is now in the right position and you can proceed with the setup of the display unit.



Fixing the barrel sensor / 6 geared Tractive gearbox.

345 or 360 degrees sensor.

Place the gearbox in the reverse gear.

Adjust the plunch so that the groove is in 90 degrees angle towards an imaginary line between the fastening holes for the sensor. Then turn the plunch 13 degrees ccw.

Before the sensor is put in place its shaft should be rotated so the mark on the shaft points at the opposite side of the connecting cable.



Document/File name MANTTT031E.doc	Document Type External	Revision 6	
First Revision, Sign and Date Lan 2002-03-12	Updated Revision, Sign and Date Bln 2018-09-03	Document Status and Sign Approved by Lan	Page 4 (4)
Document and Product Description User Manual Gear Indicator Unit TTT031			

Assembly the sensor onto the gearbox and make sure that the screws are centered in the sensors mounting holes.

Connect the display and turn on the power.

Measure with a digital voltmeter between the barrel sensor signal (cable type 1 = green, type 2 = brown) and minus (cable type 1 = blue, type 2 = black) in the 4-pole connector on the display unit. Do it both in second and third gear.

Adjust by turning the barrel sensor so that both these readings (second gear & third gear) differs the same amount compared to 2,5 volts. One higher and one lower...

When that has been done, tighten the fastening screws.

Check by measuring again that tightening the screws did not affect the sensors position.

The sensor is now in the right position and you can proceed with the setup of the display unit.

Setting up the unit

Programming gearbox levels:

Press the Black button, Level "r" and decimal point appears in green on the display. Place the gearbox in the reverse, "r", state then press the Red button. This position is now saved in memory.

Now the display shows "0" and decimal point. Place the gearbox in neutral position then press the Red button to save this position to memory.

Now the display shows "1" and decimal point. Place the gearbox in first gear position then press the Red button to save this position to memory.

Now the display shows "2" and decimal point.... Repeat until position for all gears is saved in memory.

Press the Black button to exit programming mode.

Programming the rpm limit for the display to turn from green to red:

Press the Red button, the display now shows the rpm limit value x1000 in red. Then press the Black button until the wanted x1000 value appears on the display. Press the Red button to save this value in memory.

The display now shows the rpm limit value x100 in red. Then press the Black button until the wanted x100 value appears on the display. Press the Red button to save this value in memory.

The display now shows the number of pulses/revolution and the decimal point. Press the Black button until the wanted value appears on the display. Use 2 for four cylinder motor, 3 for six cylinder motor and 4 for eight cylinder motor. Press the Red button to save this value in memory and exit the programming mode.

Note: Disconnect the programming buttons after programming is done!